

COMPRESSED AIR FROM THE AIR CYLINDER

PREBENA®

www.prebena.com

Cordless-Air-Nailer PKT-2-J50SD-SVN for secret fixing of glazing beads with Brads type J from 16 - 50 mm (5/8" - 2")

*Optional using with
standard compressor
or compressed air cylinder*



*Specialized tool
for glazing beads*

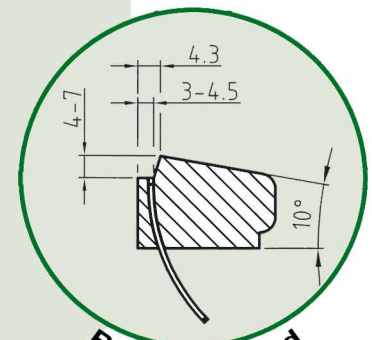
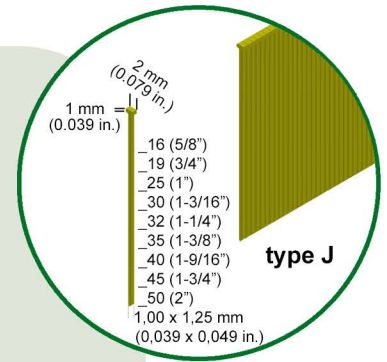

*Recommended
glazing beads
cross section*

Technical details:

Weight: 2,05 kg (4.51 lb.)
Max. pressure: 10 bar (145 psi.)
LxWxH: 350 x 71 x 275 mm
(13.78 x 2.8 x 10.83 in.)

In plastic case incl. refillable
Compressed Air Cylinder KT-1000
and adapter for use with compressor

Application:

Specialized tool for invisible fixing
of glazing beads.
Own refilling of compressed air cylinders KT-1000 with
fill station PKT-TWINTEC 400 or easy replacement at a PREBENA dealer.

*Optional using with
compressed air cylinder
or standard compressor*



Serial equipment:

- High shot capacity and shot speed
- Depth adjustment
- Single fire with safety device
- Adjustable working pressure
- Gauge for working pressure
- Gauge for air level
- Side load magazine
- Handle grip

PREBENA Wilfried Bornemann GmbH & Co. KG

Seestraße 20 - 26 • D-63679 Schotten

Phone: 0049 6044/9601 - 0 • Fax: 0049 6044/9601-820 • info@prebena.com